

DATE PLOTTED: 21 November 2023 2:07 PM BY: HOSSEINI, NELL

LEGEND

GENERAL

- PROPOSED BLOCK BOUNDARY (ACT PROPERTY GROUP ASSET)
- PROPOSED SEWER EASEMENT
- PROPOSED EXTERNAL TELECOMMUNICATIONS SERVICES
- PROPOSED EXTERNAL ELECTRICITY SERVICES
- PROPOSED INTERNAL SHARED TRENCH TELECOM AND ELECTRICITY
- PROPOSED ELECTRICAL MAIN SWITCH BOARD
- PROPOSED EXTERNAL WATERMAIN, STOP VALVE, CONCRETE THRUST BLOCK
- PROPOSED INTERNAL WATER/FIRE HYDRANT
- PROPOSED INTERNAL SEWER TIE
- PROPOSED INTERNAL STORMWATER PIPE / PLANTATION SUMP/END WALL/ECOCEPTOR
- PROPOSED EXTERNAL STORMWATER PIPE / END WALL
- DESIGN CONTOUR - MAJOR
- PROPOSED TREE

EXISTING

- SEWER / SEWER MANHOLE
- STORMWATER PIPE / SW MANHOLE STORMWATER SUMP
- EXISTING SWALE /CUTOFF DRAIN
- WATER / METER PIT / GATE VALVE DOUBLE AIR VALVE / FIRE HYDRANT
- ELECTRICAL LV (SERVICE LINE)
- ELECTRICAL HV (SERVICE LINE)
- ELECTRICAL POLE/STREETLIGHT/ STREETLIGHT OUTREACH
- EXISTING NBN
- EXISTING GOVERNMENT FIBRE OPTIC
- EXISTING CONTOUR - MAJOR
- EXISTING CONTOUR - MINOR
- EXISTING TREES TO BE RETAINED

PAVEMENT NOTES

1. REFER TO DOUGLAS PARTNERS GEOTECHNICAL INVESTIGATION REPORT, NEW GUNGAHLIN TENNIS FACILITY (MAY 2023) FOR SUBSURFACE CONDITIONS AND TREATMENT. CBR VALUES DERIVED FROM SITE SOIL TESTING AND SAMPLING.
2. SUBGRADES ARE INITIALLY TO BE PREPARED TO BOTTOM OF SELECT FILL LEVEL AND CBR TESTS TAKEN AT THIS LEVEL. FOLLOWING RECEIPT OF CBR RESULTS THE PRINCIPAL'S AUTHORISED PERSON (PAP) WILL IDENTIFY WHICH SUBGRADE AREAS REQUIRE THE SELECT FILL LAYER SHOWN IN THE PAVEMENT DESIGNS AND ASSOCIATED DEPTHS.
3. FOR ALL PAVEMENT TYPES COMPACT SUBGRADE, SELECT FILL, SUBBASE AND BASE IN ACCORDANCE WITH THE SPECIFICATION / PAVEMENT DESIGN.
4. SUBGRADE PREPARATION :
 - a. REMOVE TOPSOIL, LARGE ROOTS AND UPPER LEACHED SOILS FROM ALL AREAS TO BE PAVED.
 - b. ANY HOLES CREATED BY REMOVAL OF ROOTS SHALL BE BACKFILLED.
 - c. PROOF ROLL ALL SUBGRADES AND TOP OF SELECT FILL IN THE PRESENCE OF THE PAP AND THE CONTRACTOR'S GEOTECHNICAL ENGINEER. THE GEOTECHNICAL ENGINEER WILL ASSESS SUITABILITY OF SUBGRADE. ANY AREAS OF UNSUITABLE SUBGRADE SHALL BE REMEDIATED AS PER THE GEOTECHNICAL ENGINEER INSTRUCTIONS.
 - d. PROOF ROLL WEATHERED BEDROCK SUBGRADES.
5. FOR PAVEMENTS WITH WEATHERED BEDROCK SUBGRADE, GRADE SUBGRADE AT 3% TOWARDS EDGE.
6. ALL CONCRETE KERBING AND CHANNEL DRAIN SURFACES THAT ARE TO BE OVERLAIN BY SYNTHETIC SURFACE SHALL BE PRIMED PRIOR TO PLACEMENT OF SYNTHETIC SURFACE.
7. ALL DESIGN SUBGRADE CBR VALUES MUST BE CONFIRMED BY THE CONTRACTOR PRIOR TO COMMENCING CONSTRUCTION.
8. THE COMPACTION REQUIREMENTS FOR EARTHWORKS, SUBGRADES, AND PAVEMENT LAYERS ARE NOMINATED IN THE SPECIFICATION / PAVEMENT DESIGN.
9. RESULTS OF ADDITIONAL SUBGRADE TESTS MUST BE MADE AVAILABLE TO THE PAP WITHIN 24 HOURS OF RECEIPT. IF THE RESULT IS LESS THAN CURRENTLY NOTED THEN A PAVEMENT RE-DESIGN WILL BE REQUIRED BEFORE PROCEEDING.
10. ALL EARTHWORKS FOR TENNIS FACILITY SHALL BE UNDERTAKEN UNDER LEVEL 1 SUPERVISION TO AS 3798. REFER SPECIFICATION.

FOOTPATH CONSTRUCTION NOTES

1. EXPANSION JOINTS (EJ) SHALL BE FILLED WITH 10mm THICK BIFB OR POLYETHYLENE FOR THE FULL DEPTH OF THE PAVING. FOOTPATH EJS TO BE LOCATED OPPOSITE KERB EJS, ADJACENT TO DRIVEWAYS, VEHICULAR CROSSINGS, PRAM CROSSINGS, KERBSIDE SUMPS, AT PATH INTERSECTIONS AND ELSE WHERE AT 6 METRE CENTRES (UNLESS OTHERWISE SPECIFIED OR DIRECTED).
2. WEAKENED PLANE JOINTS (WJ) SHALL BE 3mm WIDE AND TO 1/4 THE DEPTH OF PAVING. SPACING OF WJ'S TO APPROXIMATE THE WIDTH OF PATH.
3. CONSTRUCTION JOINTS (CJ) SHALL BE PROVIDED AGAINST EXISTING CONCRETE CONSTRUCTION, EXCEPT WHERE EJ IS SPECIFIED.
4. ALL PAVING SHALL BE CURED CONTINUOUSLY FOR 3 DAYS.

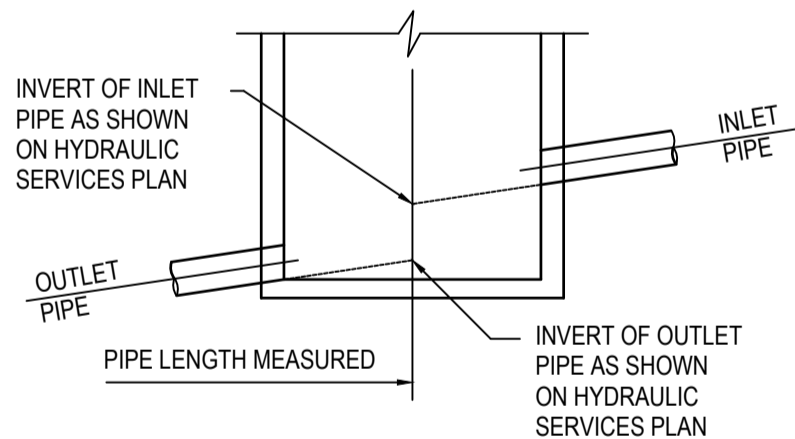

DETAIL OF INVERT LEVELS SUMPS AND MANHOLES

NOT TO SCALE

CONCRETE NOTES

1. ALL WORKMANSHIP AND MATERIALS SHALL BE IN ACCORDANCE WITH AS3600.
2. CONCRETE CHARACTERISTICS

| ELEMENT | COMPRESSIVE STRENGTH | | SLUMP |
|-------------------------------|----------------------|----------------|-------|
| | fc - 28 DAYS MPa | MAX. AGG. SIZE | |
| DRAINAGE AND MINOR STRUCTURES | 25 | 20 | 70 |
| PAVING | 25 | 20 | 70 |
| KERBING | 20 | 20 | 70 |
| FOOTINGS | 25 | 20 | 70 |
| DRIVEWAY / VEHICULAR ACCESS | 32 | 20 | 70 |
3. NO 'BRECCIA' TYPE AGGREGATE TO BE USED.
4. CEMENT TYPE 'SR'.
5. ADMIXTURES : NONE TO BE USED WITHOUT THE APPROVAL OF THE PAP.
6. COMPACTION : VIBRATION ONLY.
7. SIZES OF ELEMENTS DO NOT INCLUDE THICKNESS OF APPLIED FINISHES.
8. JOINTS : LOCATE AS SHOWN OR APPROVAL BY THE PAP.
9. COVER TO REINFORCEMENT FOR CORROSION PROTECTION SHALL BE AS FOLLOWS U.N.O.

| CONCRETE COVER : | |
|------------------------|------|
| CAST AGAINST GROUND | 55mm |
| CAST ON VAPOUR BARRIER | 45mm |
| FORMED AND BACKFILLED | 35mm |
| EXPOSED EXTERNALLY | 45mm |
10. CURING OF CONCRETE : COMPLY WITH AS3799.
11. REINFORCEMENT : CONFORM TO ASINZS4671 CURRENT ADDITION WITH AMENDMENTS.

| REINFORCEMENT SYMBOLS : | |
|-------------------------|-------------------------|
| N | 400Y GRADE DEFORMED BAR |
| S | 250S GRADE DEFORMED BAR |
| R | 250R GRADE ROUND BAR |

 THE NUMBER FOLLOWING THESE SYMBOLS IS THE BAR DIAMETER IN mm.
12. REINFORCEMENT IS REPRESENTED DIAGRAMMATICALLY: IT IS NOT NECESSARILY SHOWN IN THE TRUE PROJECTION.
13. SPLICES IN REINFORCEMENT : MAKE ONLY IN THE POSITION SHOWN OBTAIN WRITTEN APPROVAL OF THE PAP FOR ANY OTHER SPLICE.
14. WELDING OF REINFORCEMENT : PERMITTED ONLY AFTER APPROVAL BY THE PAP.
15. SITE BENDING OF N BARS : COLD BENDING WITH POWER OR MECHANICAL BENDING TOOLS ONLY.
16. CONCRETE FINISHES: REFER SPECIFICATION / DESIGN DRAWINGS FOR DETAILS.
17. CONCRETE TOLERANCES TO AUSPEC R71
18. COLOUR CONTROL: CLASS 2.

SUBSOIL DRAINAGE NOTES

1. SUBSOIL DRAIN SHALL BE 100mm DIAMETER, TYPE 1 CORRUGATED CLASS S84 PIPE IN ACCORDANCE WITH AS2439, PART 1. WITHOUT A FILTER SOCK.
2. CONNECT SUBSOIL DRAINS TO STORMWATER MANHOLES WITH Ø100 PVC-U SN10 PIPE.
3. PROVIDE A FLUSHING POINT TO ALL HIGH POINT TERMINATIONS OF SUBSOIL DRAINS REFER DETAIL ON DRG No 50518093-C-1060.
4. SUBSOIL DRAINS SHALL HAVE A MINIMUM FALL OF 0.5% UNLESS NOTED OTHERWISE.

NOTATION

| | | | |
|------|---------------------------------|-----|--------------------------------|
| BC | BRANCH CONNECTION | IP | INTERSECTION POINT |
| BE | BULK EARTHWORKS | K | KERB LEVEL |
| BIFB | BITUMEN IMPREGNATED FIBRE BOARD | KJ | KEYED JOINT |
| CJ | CONSTRUCTION JOINT | LP | LOW POINT |
| CL | COVER LEVEL | MH | MANHOLE |
| CTR | CENTRE | OCI | OPEN CONCRETE INVERT |
| CTB | CONCRETE THRUST BLOCK | P | PAVEMENT LEVEL |
| EJ | EXPANSION JOINT | PC | PRAM CROSSING |
| FRC | FIBRE REINFORCED CEMENT | PVC | PLASTICISED POLYVINYL CHLORIDE |
| FSL | FINISHED SURFACE LEVEL | QCV | QUICK COUPLING VALVE |
| G | GRATE LEVEL | RL | REDUCED LEVEL |
| GS | GRATED SUMP | RRJ | RUBBER RING JOINT |
| H | HYDRANT | SCJ | SOLVENT CEMENT JOINTS |
| HD | HEAVY DUTY | SS | SUBSOIL DRAIN |
| HER | HIGH END RISER | TP | TANGENT POINT |
| HP | HIGH POINT | WJ | WEAKENED PLANE JOINT |
| | | IL | INVERT LEVEL |

STORMWATER PIPE NOTES

1. 100mm DIAMETER: PVC-U CLASS "SN10" AND 150mm DIAMETER: PVC-U CLASS "SN8" TO AS1254 WITH SOLVENT WELDED JOINTS EXCEPT WHERE RUBBER RING JOINTS ARE REQUIRED ADJACENT TO SUMPS TO ALLOW MOVEMENT.
2. 225mm TO 600mm DIAMETER: RCP, VCP, RIBLOC 2000 OR FRC CLASS '4', ALL WITH RUBBER RING JOINTS.
3. ALL JUNCTIONS SHALL BE MADE WITH MANUFACTURED FITTINGS.
4. CONNECTION TO STORMWATER PIPES WITH A BRANCH CONNECTION OF Ø100, Ø150 OR Ø225 SHALL BE WITH MANUFACTURED FITTING OR FRC SADDLE ADAPTOR.
5. MINIMUM GRADES ON Ø100, Ø150 AND Ø225 STORMWATER SHALL BE 1.0% UNLESS NOTED OTHERWISE.
6. ALL PIPE LENGTHS, PIPE INVERTS AND LEVELS AND GRADES ARE MEASURED AT CENTRE OF STRUCTURES.

STORMWATER STRUCTURE NOTES

1. OFFSETS, WHERE SHOWN ARE TO THE CENTERLINE OF THE STORMWATER STRUCTURE.
2. CO-ORDINATES WHERE SHOWN ARE TO THE CENTRE OF THE STORMWATER STRUCTURE.
3. COVER LEVELS WHERE SHOWN ARE FOR GUIDANCE ONLY.
4. CONTRACTOR SHALL ALLOW TO CONSTRUCT THE COVERS ON A SLOPE TO SUIT THE FINAL SURFACE SHAPES AND FALLS.
5. ALL COVERS SHALL BE CLASS 'D' TO AS 3996 UNLESS NOTED OTHERWISE.

STORMWATER PIPE NOTATION

| | |
|---------|-------------------------|
| 316.58 | UPSTREAM INVERT LEVEL |
| 450 -2' | PIPE DIAMETER, CLASS |
| 38.0 m | PIPE LENGTH |
| 0.50 % | PIPE GRADE |
| 316.87 | DOWNSTREAM INVERT LEVEL |

STORMWATER PIPE MAINTENANCE NOTES

1. STORMWATER LINES SHALL BE FLUSHED OUT AND SAND OR SILT REMOVED FROM BASE OF PITS IMMEDIATELY FOLLOWING CONSTRUCTION.

SURVEY

1. A STATE SURVEY MARK (E.G. PM, SS ETC) OR BOUNDARY REFERENCE MARK MUST NOT BE DESTROYED OR DAMAGED UNLESS AUTHORISATION HAS BEEN GIVEN BY THE SURVEYOR GENERAL AND THE MARKS ARE ASSESSED BY A REGISTERED SURVEYOR OR PERSON AUTHORISED BY THE SURVEYOR GENERAL'S DEPARTMENT. ALL OTHER SURVEY MARKS ARE NOT TO BE DISTURBED OR DESTROYED UNTIL ASSESSED BY THE SITE SURVEYOR.
2. THE CONTRACTOR SHALL CHECK SUSTAINABILITY OF THE STATED COORDINATES PRIOR TO THE COMMENCEMENT OF CONSTRUCTION.
3. ANY STATE SURVEY MARK (E.G. PM, SS ETC) THAT ARE DESTROYED ARE TO BE REPLACED WITH ANOTHER STATE SURVEY MARK AS PER THE SURVEYOR GENERAL'S DIRECTIONS. PRESERVATION OF SURVEY INFRASTRUCTURE.
4. A PLAN OF SURVEY INFORMATION ONLY MUST BE PREPARED BY A REGISTERED SURVEYOR PRIOR TO ANY BOUNDARY REFERENCE MARK BEING DESTROYED OR DISTURBED.
5. ONLY ESTABLISHED STATE SURVEY MARKS ARE TO BE USED TO ESTABLISH HORIZONTAL AND HEIGHT CONTROL UNLESS THE MARK HAS BEEN APPROVED BY COUNCIL PRIOR TO CONSTRUCTION.

GENERAL NOTES

1. ALL CONSTRUCTION WORK SHALL BE CARRIED OUT IN ACCORDANCE WITH THE CONSTRUCTION SPECIFICATIONS. WHERE DIFFERENCES EXIST BETWEEN THE PLANS AND THE AUSPEC REQUIREMENTS, THESE PLANS SHALL TAKE PRECEDENCE.
2. ALL CONSTRUCTION WORK SHALL BE CO-ORDINATED WITH ADJACENT CONTRACTS AND WORKS. ALL DRAWINGS SHALL BE READ IN CONJUNCTION WITH ANY ARCHITECTURAL, CIVIL, HYDRAULICS AND ELECTRICAL DRAWINGS.
3. THE LOCATION OF SOME EXISTING SERVICES ARE SHOWN IN THEIR APPROXIMATE LOCATION ONLY. PRIOR TO ANY DEMOLITION, EXCAVATION, OR CONSTRUCTION ON SITE, THE CONTRACTOR SHALL CONTACT THE RELEVANT AUTHORITIES AND VERIFY THE LOCATION OF ALL UNDERGROUND SERVICES ON THE SITE AND OBTAIN NECESSARY CLEARANCES.
4. SURFACES WHICH LIE OUTSIDE THE GENERAL LIMITS OF LANDSCAPING AND RESTORATION WHICH ARE DISTURBED DURING THE CONSTRUCTION OF THE WORKS SHALL BE RESTORED BY THE CONTRACTOR, AT THE CONTRACTOR'S EXPENSE, TO AT LEAST THEIR PRE-CONSTRUCTION CONDITION. THESE SURFACES INCLUDE, BUT ARE NOT NECESSARILY LIMITED TO, PAVEMENTS, PAVING, GRASSING, LANDSCAPING ETC.
5. ALL LEVELS SHOWN ARE FINISHED LEVELS PROVIDED IN THIS CONTRACT. THE CONTRACTOR SHALL ALLOW FOR THE THICKNESS OF ALL FINISHED SURFACES.
6. ALL LEVELS ARE IN METRES TO AHD. ALL COORDINATES ARE IN METRES.
7. NO VEGETATION SHALL BE REMOVED WITHOUT PRIOR APPROVAL OF THE PAP UNLESS NOTED ON THE DRAWINGS OR SCHEDULED IN THE REVIEW OF ENVIRONMENTAL FACTORS.
8. THE IMPACT ON THE ENVIRONMENT SHALL BE MINIMISED BY OBSERVING THE FOLLOWING MINIMUM CONSTRUCTION,
 - * AREAS DISTURBED BY CONSTRUCTION TRAFFIC AND PROCEDURES SHALL BE MINIMISED.
 - * HYDROMULCHING (OR ALTERNATIVE APPROVED TREATMENT) FOR SOLE STABILISATION SHALL BE CARRIED OUT SOON AFTER THE COMPLETION OF TOPSOIL PLACEMENT.
 - * FLOW DIVERSION SHALL BE CARRIED OUT BY EARLY INSTALLATION OF DRAINS ALONG TOPS OF BATTERS WITH APPROPRIATE SILTATION CONTROL DEVICES IN ACCORDANCE WITH STANDARD DRAWING ASD602.
 - * SEDIMENT INTERCEPTION BY THE PLACEMENT OF TEMPORARY SILT FENCING AND GRAVEL FILLED GEOTEXTILE SAUSAGES ACROSS DRAINAGE LINES AND AT INTERCEPTION POINTS FOR BOTH THE CONSTRUCTION AND STOCKPILE AREAS IN ACCORDANCE WITH STANDARD DRAWING ASD601.
 - * INSTALLATION OF SEDIMENT TRAPS AT GRATED PITS AND KERB INLET PIT IN ACCORDANCE WITH STANDARD DRAWING ASD600.
9. SETOUT AND POINT INFORMATION TO BE PROVIDED IN ELECTRONIC FORMAT UPON REQUEST TO THE CONSTRUCTION SURVEYOR AT THE TIME OF CONSTRUCTION.
10. CONTRACTOR TO CONFIRM LEVELS OF EXISTING SERVICES AT ALL CROSSINGS AND IN THE PROXIMITY OF EXCAVATIONS PRIOR TO COMMENCING EXCAVATION.
11. AS CONSTRUCTED DETAILS SHALL BE RECORDED BY A REGISTERED SURVEYOR OR APPROVED ENGINEERING SURVEYOR AT THE CONTRACTOR'S COST. AS CONSTRUCTED DETAILS SHALL BE SUBMITTED TO THE PAP PRIOR TO PRACTICAL COMPLETION.

REFERENCES:

- AUSTROADS - PAVEMENT DESIGN MANUAL
- AUSTROADS - GUIDE TO ROAD DESIGN SUITE
- AUSTRALIAN STANDARDS - AS 1742 MANUAL OF UNIFORM TRAFFIC CONTROL DEVICES
- AUSTRALIAN STANDARDS - AS 1428 DESIGN FOR ACCESS & MOBILITY
- AUSTRALIAN STANDARDS - AS 2439 PERFORATED PLASTICS DRAINAGE AND EFFLUENT PIPE AND FITTINGS
- AUSTRALIAN STANDARDS - AS 4883 SEWER
- AUSTRALIAN STANDARDS - AS 3718 WATER PART 1 (PERFORATED PLASTICS DRAINAGE AND EFFLUENT PIPES AND FITTINGS)

| Rev. | Date | Description | Des. | Verif. | Appd. |
|------|------------|-------------------|------|--------|--------|
| B | 13/11/2023 | FOR APPROVAL | | TM | GZ JPS |
| A | 23/05/2023 | FINAL SKETCH PLAN | | TM | GZ JPS |



© Stantec Limited All Rights Reserved.
This document is produced by Stantec Limited solely for the benefit of and use by the client in accordance with the terms of the retainer. Stantec Limited does not and shall not assume any responsibility or liability whatsoever to any third party arising out of any use or reliance by third party on the content of this document.



| | | |
|-----------------|--------------------|---------------------------------------------------------------------------|
| Drawn NH | Date 23/05/2023 | Client Chief Minister, Treasury and Economic Development Directorate |
| Checked AS | Date 23/05/2023 | Project NEW GUNGAHLIN TENNIS FACILITY |
| Designed TM | Date 23/05/2023 | Development Application (AMAROO, BLOCK 4, SECTION 109 - NORTHERN SIDE) |
| Verified GZ | Date 23/05/2023 | Title GENERAL NOTES |
| Approved JPS | Date 23/05/2023 | Status FOR APPROVAL NOT TO BE USED FOR CONSTRUCTION PURPOSES |
| | | Page No. 3.01 |
| | | Datum AHD |
| | | Scale NTS |
| | | Size A1 |
| | | Drawing Number 304000930-GNL-1002 |
| | | Revision B |

CAD File: C:\Project\Wise-Drive\Stantec\304100000\304000930\Drawings\Build\FSP\304000930-FSP-1002-GNL.dwg